

User Guide

# Modbus protocol for Mega & Mega E, Genesis platform

Version 17.1



The English language is used for the original instructions.  
Other languages are a translation of the original instructions.  
(Directive 2006/42/EC)

© Copyright Thermia AB

**Table of Contents**

<b>1</b>	<b>Connecting Modbus</b> .....	<b>4</b>
1.1	Connecting Modbus .....	4
<b>2</b>	<b>Scale, function, negative numbers &amp; MSB/LSB</b> .....	<b>5</b>
2.1	Scale, function, negative numbers & MSB/LSB .....	5
2.2	Addressing .....	6
2.3	Factory default .....	6
2.4	Table key .....	7
<b>3</b>	<b>Address list</b> .....	<b>8</b>
3.1	Read/Write Digital Registers .....	8
3.2	Read Digital Registers .....	9
3.3	Read Analog Registers .....	13
3.4	Read/Write Analog Registers .....	17
<b>4</b>	<b>Heat pump unit</b> .....	<b>22</b>
4.1	Heat pump unit .....	22
<b>5</b>	<b>Heat</b> .....	<b>28</b>
5.1	Heating system .....	28
5.2	Mix valve 1 .....	29
5.3	Mix valve 2 .....	29
5.4	Mix valve 3 .....	30
5.5	Mix valve 4 .....	31
5.6	Mix valve 5 .....	32
<b>6</b>	<b>Tap water</b> .....	<b>34</b>
6.1	Tap water .....	34
6.2	TWC .....	34
6.3	WCS .....	35
<b>7</b>	<b>Cooling</b> .....	<b>36</b>
7.1	Cooling .....	36
7.2	Cooling tank .....	36
7.3	Cooling circuit .....	36
7.4	Surplus heat .....	37
<b>8</b>	<b>Pool</b> .....	<b>38</b>
8.1	Pool .....	38
<b>9</b>	<b>Electric meter</b> .....	<b>39</b>
9.1	Electric meter .....	39
<b>10</b>	<b>RSM - Refrigerant Safety Module</b> .....	<b>40</b>
10.1	RSM - Refrigerant Safety Module .....	40
<b>11</b>	<b>Footnotes</b> .....	<b>41</b>
11.1	Footnotes .....	41

## 1 Connecting Modbus

---

### 1.1 Connecting Modbus

---

The heat pump supports two Modbus protocols:

- Modbus RTU (connect to the BM-card (Port: MBe) located in the electrical cabinet)
- Modbus TCP/IP (connect to the RJ45 connection located on the display unit)

The settings for Modbus parameters can be found under Settings / BMS in the display.

For Modbus TCP/IP, if you have secondary units, you will need a network switch or router since the primary/secondary interface uses the same RJ45 connector for its communication. Make sure that you are not using the same port as the Primary uses to communicate to its secondaries.

## 2 Scale, function, negative numbers & MSB/LSB

### 2.1 Scale, function, negative numbers & MSB/LSB

Scale	
1	No conversion factor
10	Conversion factor 10, i.e. the transmitted value is a tenfold larger
100	Conversion factor 100, i.e. the transmitted value is a tenfold larger

Function	Function	Description
1	Read Coil Status	Read one or more consecutive boolean registers
2	Read Input Status	Read one or more consecutive boolean registers
3	Read Holding Registers	Read one or more consecutive analog registers
4	Read Input Registers	Read one or more consecutive analog registers
5	Force Single Coil	Write to one boolean register
6	Preset Single Holding Register	Write to one analog register
15	Force Multiple Coils	Write one or more consecutive boolean registers
16	Preset Multiple Holding Registers	Write one or more consecutive analog registers

#### Negative numbers

Negative numbers are represented by the upper half of each 16 bit register.

```

100 = 100
...
2 = 2
1 = 1
0 = 0
-1 = 65535
-2 = 65534
-3 = 65533
...
-100 = 65436
etc.

```

Example: if "Brine out low alarm limit" register is set to -5 °C then, since the register has a scale of 100, the value read on Modbus should be 65036, representing -500.

Observe that not all variables are signed, i.e. "Compressor operating hours (LSB)" is a strict positive number between 0 to 65535.

#### MSB/LSB

Some variables has potential to surpass their maximum value, for instance the variable "Compressor operating hours" can become larger than 65535.

For these specific variables, that might be affected by this, there are two registers, MSB (Most Significant Bit) and LSB (Least Significant Bit) that can be combined in order to get a 32 bit number representation of the value.

i.e. "Compressor operating hours" is separated in to "Compressor operating hours (MSB)" and "Compressor operating hours (LSB)". The LSB register is counting up by 1 for each hour that the compressor has been running and when it reaches 65535 then it will add 1 to the MSB register and reset the LSB register.

In order to obtain the total Compressor operating hours then the two registers are combined into a 32 bit register where the MSB address represents the upper 16 bits and LSB represents the lower 16 bits.

Example:

Compressor operating hours (MSB) = 2  
 Compressor operating hours (LSB) = 2345  
 Total Compressor operating hours =  $2 \times 65536$  (MSB) + 2345 (LSB) = 133417 hours

## 2.2 Addressing

A "De Facto-standard" have come to be with the purpose of simpler integration. Addressing is done as follows:

First variable of	Is addressed	Typical function(s)
COIL STATUS	00001	1, 5 (5=write)
INPUT STATUS	10001	2
HOLDING REGISTERS	40001	3, 6 (6=write)
INPUT REGISTERS	30001	4

Observe that some systems cannot handle aforementioned addressing system. Commonly a combination of function and absolute reference to 0 is used. The address table shows both alternatives.

## 2.3 Factory default

Parameter	Factory	Range
Speed	19200 bps	19200 (2400,4800,9600, 14400, 19200, 28800, 38400, 57600, 115200)
Parity	Even	Even, none, odd
Address	1	1-247, not implemented on Modbus TCP/IP, the heat pump will respond to each address on its specific IP-address using the designated modbus port
Start bit	1	1
Stop bit	1	1 stop bit when Even or Odd Parity and optional when Parity None is chosen
Data bit	8	Data bits can only be 8 bits
Port	502	1-65535
Modbus mode	RTU	RTU, TCP/IP

## 2.4 Table key

Reference to	
1	Heating system
2	Hot water
3	TWC
4	WCS
5	Cooling
6	Pool
7	Distribution circuit
8	Buffer tank
9	Electric meter
10	Internal heat pump
11	RSM - Refrigerant Safety Module. Only for Mega E

**Position number** Refers to the number in the system proposals as the example below.

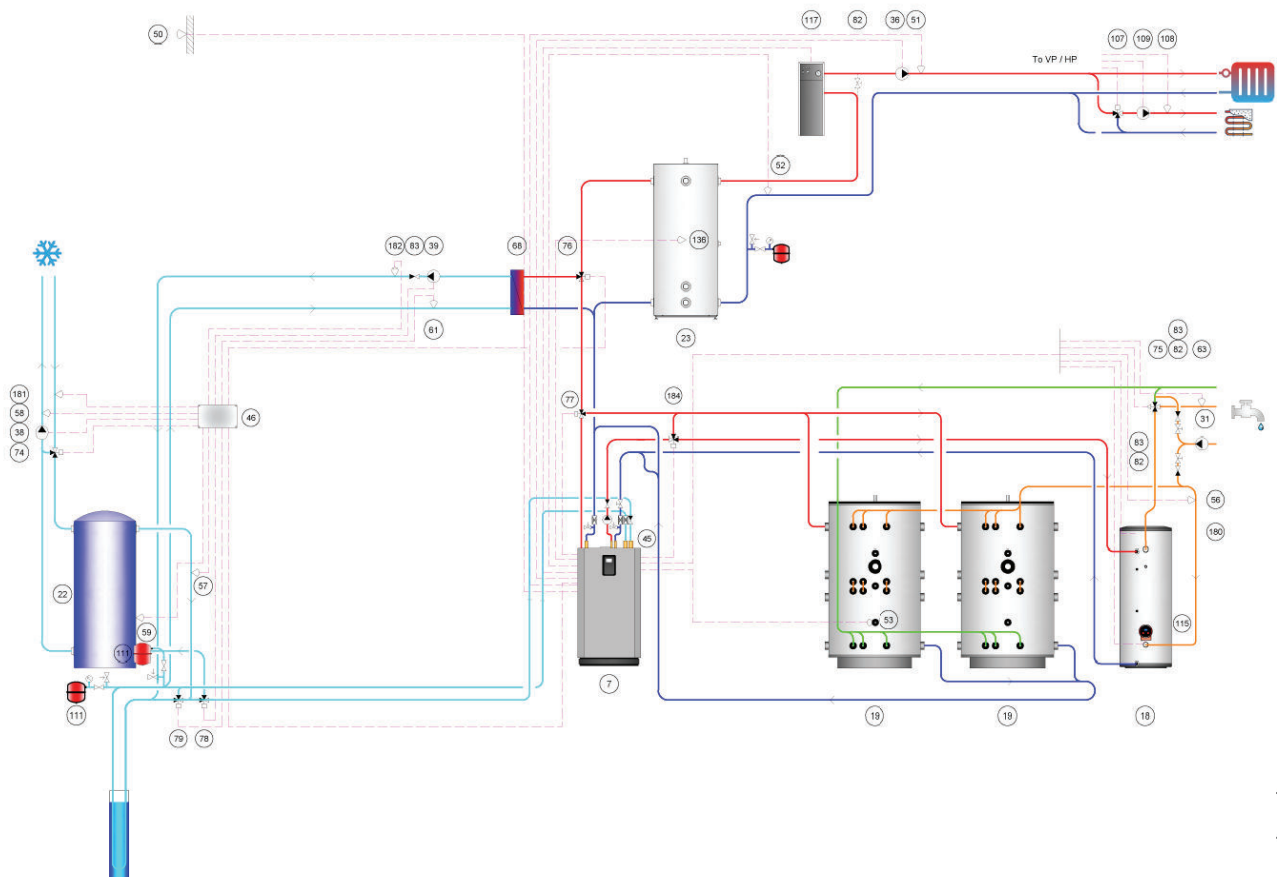

## 3 Address list

### 3.1 Read/Write Digital Registers

COILS - Function codes: 1=read coils, 5=write single coil, 15=write multiple coils						
Position number	Units	Reference to	Address	De Facto Address	Scale	Description
	active/ inactive		3	4	1	Reset all alarms
117	on/off	1	5	6	1	Enable external additional heater
71	on/off		7	8	1	Enable flow switch/pressure switch
	on/off	2	8	9	1	Enable tap water
	on/off	1	9	10	1	Enable heat
	on/off	5	10	11	1	Enable active cooling
107	on/off	7	11	12	1	Enable mix valve 1
	on/off	3	12	13	1	Enable TWC (EM)
	on/off	4	13	14	1	Enable WCS (EM)
34	on/off		14	15	1	Enable hot gas pump
207	on/off	7	16	17	1	Enable mix valve 2 (EM)
207	on/off	7	17	18	1	Enable mix valve 3 (EM)
207	on/off	7	18	19	1	Enable mix valve 4 (EM)
207	on/off	7	19	20	1	Enable mix valve 5 (EM)
	on/off		20	21	1	Enable brine out monitoring
	on/off		21	22	1	Enable brine pump continuous operation
36	on/off	1	22	23	1	Enable system circulation pump
	on/off		23	24	1	Enable dew point calculation (EM)
117	on/off	1	25	26	1	Enable additional heater only (No compressor). Requires Operation mode: Standby
	on/off		26	27	1	Enable current limitation
	on/off	6	28	29	1	Enable pool (EM)
	on/off	5	29	30	1	Enable surplus heat, chiller (no borehole)
	on/off	5	30	31	1	Enable surplus heat, borehole (no chiller)
	on/off	6	31	32	1	Enable external additional heater for pool (EM)
	on/off	5	33	34	1	Enable passive cooling (EM)
	on/off	10	34	35	1	Enable variable speed mode for condenser pump
	on/off	10	35	36	1	Enable variable speed mode for brine pump
207	on/off		37	38	1	Enable outdoor temp dependent for cooling with mixing valve 1
	on/off		38	39	1	Enable internal brine pump to start when cooling is active for mixing valve 1
	on/off	1	39	40	1	Enable outdoor temp dependent for external heater
	on/off		40	41	1	Enable brine in monitoring
	on/off		41	42	1	Enable fixed system supply set point, allows defacto address 40117
	on/off		42	43	1	Enable evaporator freeze protection
	on/off		43	44	1	Enable outdoor temp dependent for cooling with mixing valve 2 (EM3 only)*5
	on/off		44	45	1	Enable dew point calculation on mixing valve 2, requires room sensor for mixing valve 2 (EM3 only)
	on/off		45	46	1	Enable outdoor temp dependent for heating with mixing valve 2 (EM3 only)*5

COILS - Function codes: 1=read coils, 5=write single coil, 15=write multiple coils						
Position number	Units	Reference to	Address	De Facto Address	Scale	Description
	on/off		46	47	1	Enable outdoor temp dependent for cooling with mixing valve 3 (EM3 only)*5
	on/off		47	48	1	Enable dew point calculation on mixing valve 3, requires room sensor for mixing valve 3 (EM3 only)
	on/off		48	49	1	Enable outdoor temp dependent for heating with mixing valve 3 (EM3 only)*5
	on/off		49	50	1	Enable outdoor temp dependent for cooling with mixing valve 4 (EM3 only)*5
	on/off		50	51	1	Enable dew point calculation on mixing valve 4, requires room sensor for mixing valve 4 (EM3 only)
	on/off		51	52	1	Enable outdoor temp dependent for heating with mixing valve 4 (EM3 only)*5
	on/off		52	53	1	Enable outdoor temp dependent for cooling with mixing valve 5 (EM3 only)*5
	on/off		53	54	1	Enable dew point calculation on mixing valve 5, requires room sensor for mixing valve 5 (EM3 only)
	on/off		54	55	1	Enable outdoor temp dependent for heating with mixing valve 5 (EM3 only)*5
	on/off		55	56	1	Enable internal brine pump to start when cooling is active for mixing valve 2 (EM3 only)
	on/off		56	57	1	Enable internal brine pump to start when cooling is active for mixing valve 3 (EM3 only)
	on/off		57	58	1	Enable internal brine pump to start when cooling is active for mixing valve 4 (EM3 only)
	on/off		58	59	1	Enable internal brine pump to start when cooling is active for mixing valve 5 (EM3 only)
	on/off		59	60	1	Enable continuous operation mode for condenser pump.
	on/off		60	61	1	Allow current limiter to restrict external additional heater
	on/off		61	62	1	Allow current limiter to restrict secondary heat pump units
	on/off		63	64	1	External brine pump control - Enable delta control (EM)
	on/off		64	65	1	External brine pump control - Intermediate heat exchanger (EM)

### 3.2 Read Digital Registers

DISCRETE INPUTS - Function codes: 2=read discrete inputs						
Position number	Units	Reference to	Address	De Facto Address	Scale	Description
	active/ inactive		0	10001	1	Alarm active, Class: A
	active/ inactive		1	10002	1	Alarm active, Class: B
	active/ inactive		2	10003	1	Alarm active, Class: C
	active/ inactive		3	10004	1	Alarm active, Class: D - Genesis secondary
	active/ inactive		4	10005	1	Alarm active, Class: E - Legacy secondary
	active/ inactive	10	9	10010	1	High pressure switch alarm

DISCRETE INPUTS - Function codes: 2=read discrete inputs						
Position number	Units	Reference to	Address	De Facto Address	Scale	Description
	active/ inactive	10	10	10011	1	Low pressure level alarm
	active/ inactive	10	11	10012	1	High discharge pipe temperature alarm
	On/Off	10	12	10013	1	Operating pressure limit indication
	active/ inactive	10	13	10014	1	Discharge pipe sensor alarm
	active/ inactive	10	14	10015	1	Liquid line sensor alarm
	active/ inactive	10	15	10016	1	Suction gas sensor alarm
71	active/ inactive		16	10017	1	Flow/pressure switch alarm
	active/ inactive		22	10023	1	Power input phase detection alarm
	active/ inactive	10	23	10024	1	Inverter unit alarm
51	active/ inactive	1	24	10025	1	System supply low temperature alarm
	active/ inactive	10	25	10026	1	Compressor low speed alarm
	active/ inactive	10	26	10027	1	Low super heat alarm
	active/ inactive	10	27	10028	1	Pressure ratio out of range alarm
	active/ inactive	10	28	10029	1	Compressor pressure outside envelope alarm
	active/ inactive		29	10030	1	Brine temperature out of range alarm
	active/ inactive	10	30	10031	1	Brine in sensor alarm
	active/ inactive	10	31	10032	1	Brine out sensor alarm
	active/ inactive	10	32	10033	1	Condenser in sensor alarm
	active/ inactive	10	33	10034	1	Condenser out sensor alarm
50	active/ inactive		34	10035	1	Outdoor sensor alarm
51	active/ inactive	1	35	10036	1	System supply line sensor alarm
108	active/ inactive	7	36	10037	1	Mix valve 1 supply line sensor alarm
208	active/ inactive	7	37	10038	1	Mix valve 2 supply line sensor alarm (EM)
208	active/ inactive	7	38	10039	1	Mix valve 3 supply line sensor alarm (EM)
208	active/ inactive	7	39	10040	1	Mix valve 4 supply line sensor alarm (EM)
208	active/ inactive	7	40	10041	1	Mix valve 5 supply line sensor alarm (EM)

DISCRETE INPUTS - Function codes: 2=read discrete inputs						
Position number	Units	Reference to	Address	De Facto Address	Scale	Description
54	active/ inactive	4	44	10045	1	WCS return line sensor alarm (EM)
63	active/ inactive	3	45	10046	1	TWC supply line sensor alarm (EM)
59	active/ inactive	5	46	10047	1	Cooling tank sensor alarm (EM)
58	active/ inactive	5	47	10048	1	Cooling supply line sensor alarm (EM)
181	active/ inactive	5	48	10049	1	Cooling circuit return line sensor alarm (EM)
	active/ inactive		49	10050	1	Brine delta out of range alarm
53	active/ inactive	2	50	10051	1	Tap water mid sensor alarm
56	active/ inactive	3	51	10052	1	TWC circulation return sensor alarm (EM)
	active/ inactive		56	10057	1	Brine in low temperature alarm
	active/ inactive		57	10058	1	Brine out low temperature alarm
56	active/ inactive	3	58	10059	1	TWC circulation return low temperature alarm (EM)
63	active/ inactive	3	59	10060	1	TWC supply low temperature alarm (EM)
108	active/ inactive	7	60	10061	1	Mix valve 1 supply temperature deviation alarm
208	active/ inactive	7	61	10062	1	Mix valve 2 supply temperature deviation alarm (EM)
208	active/ inactive	7	62	10063	1	Mix valve 3 supply temperature deviation alarm (EM)
208	active/ inactive	7	63	10064	1	Mix valve 4 supply temperature deviation alarm (EM)
208	active/ inactive	7	64	10065	1	Mix valve 5 supply temperature deviation alarm (EM)
54	active/ inactive	4	65	10066	1	WCS return line temperature deviation alarm (EM)
	active/ inactive		66	10067	1	Sum alarm
58	active/ inactive	5	67	10068	1	Cooling circuit supply line temperature deviation alarm (EM)
59	active/ inactive	5	68	10069	1	Cooling tank temperature deviation alarm (EM)
182	active/ inactive	5	69	10070	1	Surplus heat temperature deviation alarm (EM)
422	active/ inactive	5	70	10071	1	Humidity room sensor alarm
182	active/ inactive	5	71	10072	1	Surplus heat supply line sensor alarm (EM)
61	active/ inactive	5	72	10073	1	Surplus heat return line sensor alarm (EM)
57	active/ inactive	5	73	10074	1	Cooling tank return line sensor alarm (EM)

DISCRETE INPUTS - Function codes: 2=read discrete inputs						
Position number	Units	Reference to	Address	De Facto Address	Scale	Description
62	active/ inactive		74	10075	1	Temperature room sensor alarm
	active/ inactive	10	75	10076	1	Inverter unit communication alarm
60	active/ inactive	6	76	10077	1	Pool return line sensor alarm
	on/off	6	77	10078	1	External stop for pool, read only (EM)
	on/off		78	10079	1	External start brine pump, read only
	on/off		79	10080	1	External relay for brine/ground water pump.
180	active/ inactive	2	81	10082	1	Tap water end tank sensor alarm
	active/ inactive		83	10084	1	Genesis secondary unit alarm - this specific secondary unit can't communicate with its primary unit
	active/ inactive		84	10085	1	Primary unit alarm - the primary has detected other primary units on the same network with a network mask that is allowing conflict. Change network settings in order to avoid problem. For instance change port number on the primary and its secondary unit.
	active/ inactive		85	10086	1	Primary unit alarm - the primary has not detected all secondary units. Make sure that the primary/secondary settings are correct and the network mask and port and number of Genesis secondaries settings are correct.
	on/off	10	86	10087	1	Oil boost in progress
	active/ inactive		87	10088	1	Tap water top sensor alarm.
	on/off	10	199	10200	1	Compressor control signal
	on/off		201	10202	1	Smart Grid 1, EVU input
	active/ inactive		202	10203	1	External alarm input
	on/off		204	10205	1	Smart Grid 2
117	on/off	1	206	10207	1	External additional heater control signal
109	on/off	7	209	10210	1	Mix valve 1 circulation pump control signal
	on/off	10	210	10211	1	Condenser pump On/off control
36	on/off	1	211	10212	1	System circulation pump control signal
34	on/off		213	10214	1	Hot gas circulation pump control signal
	on/off	10	218	10219	1	Brine pump On/off control
176	on/off	1	219	10220	1	External heater circulation pump control signal
	on/off	1	220	10221	1	Heating season (winter) active
117	on/off	1	221	10222	1	External additional heater active
	on/off	10	224	10225	1	Heat pump stopping
	on/off	10	225	10226	1	Heat pump OK to start
31	on/off	3	230	10231	1	TWC supply line circulation pump control signal (EM)
73	on/off	4	232	10233	1	WCS regulation control signal (EM)
35	on/off	4	233	10234	1	WCS circulation pump control signal (EM)
115	on/off	3	234	10235	1	TWC end tank heater control signal (EM)
101	on/off	6	235	10236	1	Pool directional valve position (EM)
38	on/off	5	236	10237	1	Cooling circuit circulation pump control signal (EM)
32	on/off	6	237	10238	1	Pool circulation pump control signal (EM)
76	on/off	5	238	10239	1	Surplus heat directional valve position (EM)

DISCRETE INPUTS - Function codes: 2=read discrete inputs						
Position number	Units	Reference to	Address	De Facto Address	Scale	Description
39	on/off	5	239	10240	1	Surplus heat circulation pump control signal (EM)
	on/off	5	240	10241	1	Cooling circuit regulation control signal (EM)
	on/off	5	241	10242	1	Surplus heat regulation control signal (EM)
79	on/off	5	242	10243	1	Active cooling directional valve position (Borehole disconnected) (EM)
78	on/off	5	243	10244	1	Passive/Active cooling directional valve position (Cooling tank connected) (EM)
	on/off	6	244	10245	1	Pool regulation control signal (EM)
	on/off		245	10246	1	Indication when mixing valve 1 is producing passive cooling
	on/off	10	246	10247	1	Compressor is unable to speed up
	active/inactive	11	247	10248	1	Refrigerant safety module internal failure. Only for Mega E.
	active/inactive	11	248	10249	1	Refrigerant safety module internal failure. Only for Mega E.
	active/inactive	11	249	10250	1	Ventilation test failed, pressure sensor triggered prior to started test. Only for Mega E.
	active/inactive	11	250	10251	1	Ventilation test failed, pressure sensor did not trigger during the test. Only for Mega E.
	active/inactive	11	251	10252	1	Refrigerant leakage detected. Only for Mega E.
	active/inactive	11	252	10253	1	Refrigerant leakage sensor failure. Only for Mega E.
	active/inactive	11	253	10254	1	Refrigerant safety module communication error. Only for Mega E.
	active/inactive	11	254	10255	1	Ventilation test failed. Only for Mega E.
	on/off		270	10271	1	Distribution circuit 2 pump control signal (EM)
	on/off		271	10272	1	Distribution circuit 3 pump control signal (EM)
	on/off		272	10273	1	Distribution circuit 4 pump control signal (EM)
	on/off		273	10274	1	Distribution circuit 5 pump control signal (EM)
	yes/no		274	10275	1	Compressor allowed to run status

### 3.3 Read Analog Registers

INPUT REGISTERS - Function codes: 4=read input registers						
Position number	Units	Reference to	Address	De Facto Address	Scale	Description
	enum		1	30002	1	Currently running: First prioritised demand *1
	bit field		2	30003	1	Currently running: Bit registers that shows the all the current running demands according to *6
		10	4	30005	100	Compressor available gears *3
	rpm	10	5	30006	1	Compressor speed RPM
117	%	1	6	30007	100	External additional heater: Current demand (%)
	°C	10	7	30008	100	Discharge pipe temperature
	°C	10	8	30009	100	Condenser in temperature
	°C	10	9	30010	100	Condenser out temperature
	°C	10	10	30011	100	Brine in temperature

INPUT REGISTERS - Function codes: 4=read input registers						
Position number	Units	Reference to	Address	De Facto Address	Scale	Description
	°C	10	11	30012	100	Brine out temperature
51	°C	1	12	30013	100	System supply line temperature
50	°C		13	30014	100	Outdoor temperature
55	°C	2	15	30016	100	Tap water top temperature
53	°C	2	16	30017	100	Tap water lower temperature
53/55	°C	2	17	30018	100	Tap water weighted temperature
51	°C	1	18	30019	100	System supply line calculated set point
51	°C	1	19	30020	100	Selected heat curve, (system) supply line
51	°C	1	20	30021	100	Heat curve, X-coordinate 1 (highest outdoor temperature)
51	°C	1	21	30022	100	Heat curve, X-coordinate 2
51	°C	1	22	30023	100	Heat curve, X-coordinate 3
51	°C	1	23	30024	100	Heat curve, X-coordinate 4
51	°C	1	24	30025	100	Heat curve, X-coordinate 5
51	°C	1	25	30026	100	Heat curve, X-coordinate 6
51	°C	1	26	30027	100	Heat curve, X-coordinate 7 (lowest outdoor temperature)
	°C		27	30028	100	System return line temperature.
		10	30	30031	100	Calculated demand (heat)
48	°C		31	30032	100	External brine pump control - Brine in temperature (EM)
49	°C		32	30033	100	External brine pump control - Brine out temperature (EM)
172	%		33	30034	100	External brine pump control - Pump speed in percent (EM)
		5	36	30037	1	Cooling season integral value
	%	10	39	30040	100	Condenser circulation pump speed (%)
108	°C	7	40	30041	100	Mix valve 1 supply line temperature
136	°C	8	41	30042	100	Buffer tank temperature
107	%	7	43	30044	100	Mix valve 1 position
	%	10	44	30045	100	Brine circulation pump speed (%)
77	%	2	47	30048	1	Hot water directional valve position (%)
	h	10	48	30049	1	Compressor operating hours (MSB)
	h	10	49	30050	1	Compressor operating hours (LSB)
	h	2	50	30051	1	Tap water operating hours (MSB)
	h	2	51	30052	1	Tap water operating hours (LSB)
117	h	1	52	30053	1	External additional heater operating hours (MSB)
117	h	1	53	30054	1	External additional heater operating hours (LSB)
	%	10	54	30055	100	Compressor speed percent
	enum		55	30056	1	Currently running: Second prioritised demand *1
	enum		56	30057	1	Currently running: Third prioritised demand *1
		10	57	30058	1	Software version: Major
		10	58	30059	1	Software version: Minor
		10	59	30060	1	Software version: Micro
	s	10	60	30061	1	Compressor temporarily blocked, (start restriction timer)
		10	61	30062	100	Compressor current gear
	enum		62	30063	1	Queued demand, first priority *1
	enum		63	30064	1	Queued demand, second priority *1
	enum		64	30065	1	Queued demand, third priority *1
	enum		65	30066	1	Queued demand, fourth priority *1
	enum		66	30067	1	Queued demand, fifth priority *1
317	step		67	30068	1	Active step internal immersion heater, Mega S-E only

INPUT REGISTERS - Function codes: 4=read input registers						
Position number	Units	Reference to	Address	De Facto Address	Scale	Description
51/136	°C	8	68	30069	100	Buffer tank charge set point
	A	9	69	30070	100	Electric meter L1 current (A)
	A	9	70	30071	100	Electric meter L2 current (A)
	A	9	71	30072	100	Electric meter L3 current (A)
	V	9	72	30073	100	Electric meter L1-0 voltage (V)
	V	9	73	30074	100	Electric meter L2-0 voltage (V)
	V	9	74	30075	100	Electric meter L3-0 voltage (V)
	V	9	75	30076	10	Electric meter L1-L2 voltage (V)
	V	9	76	30077	10	Electric meter L2-L3 voltage (V)
	V	9	77	30078	10	Electric meter L3-L1 voltage (V)
	W	9	78	30079	1	Electric meter L1 power (W)
	W	9	79	30080	1	Electric meter L2 power (W)
	W	9	80	30081	1	Electric meter L3 power (W)
	kWh	9	81	30082	1	Electric meter - meter value (kWh)
	enum		82	30083	1	Comfort mode *4
		9	83	30084	10	Electric meter kWh total (LSB)
		9	84	30085	10	Electric meter kWh total (MSB)
73	%	4	85	30086	100	WCS valve position (EM)
75	%	3	86	30087	100	TWC valve position (EM)
207	%	7	87	30088	100	Mix valve 2 position (EM)
207	%	7	88	30089	100	Mix valve 3 position (EM)
207	%	7	89	30090	100	Mix valve 4 position (EM)
207	%	7	90	30091	100	Mix valve 5 position (EM)
422		5	91	30092	100	Dew point room (EM)
74	%	5	92	30093	100	Cooling supply line mix valve position (EM)
119	%	5	93	30094	100	Surplus heat fan speed (EM)
101	%	6	94	30095	100	Pool supply line mix valve position (EM)
63	°C	3	95	30096	100	TWC supply line temperature (EM)
56	°C	3	96	30097	100	TWC return temperature (EM)
54	°C	4	97	30098	100	WCS return line temperature (EM)
180	°C	3	98	30099	100	TWC end tank temperature (EM)
208	°C	7	99	30100	100	Mix valve 2 supply line temperature (EM)
208	°C	7	100	30101	100	Mix valve 3 supply line temperature (EM)
208	°C	7	101	30102	100	Mix valve 4 supply line temperature (EM)
181	°C	5	103	30104	100	Cooling circuit return line temperature (EM)
59	°C	5	104	30105	100	Cooling tank temperature (EM)
57	°C	5	105	30106	100	Cooling tank return line temperature (EM)
58	°C	5	106	30107	100	Cooling circuit supply line temperature (EM)
208	°C	7	107	30108	100	Mix valve 5 supply line temperature (EM)
210	°C	7	109	30110	100	Mix valve 2 return line temperature (EM)
	°C	7	110	30111	100	Mix valve 2 room temperature, requires room sensor for mixing valve 2 (EM3 only)
210	°C	7	111	30112	100	Mix valve 3 return line temperature (EM)
	°C	7	112	30113	100	Mix valve 3 room temperature, requires room sensor for mixing valve 3 (EM3 only)
210	°C	7	113	30114	100	Mix valve 4 return line temperature (EM)

INPUT REGISTERS - Function codes: 4=read input registers						
Position number	Units	Reference to	Address	De Facto Address	Scale	Description
	°C	7	114	30115	100	Mix valve 4 room temperature, requires room sensor for mixing valve 4 (EM3 only)
210	°C	7	115	30116	100	Mix valve 5 return line temperature (EM)
	°C	7	116	30117	100	Mix valve 5 room temperature, requires room sensor for mixing valve 5 (EM3 only)
61	°C	5	117	30118	100	Surplus heat return line temperature (EM)
182	°C	5	118	30119	100	Surplus heat supply line temperature (EM)
183	°C	6	119	30120	100	Pool supply line temperature (EM)
60	°C	6	120	30121	100	Pool return line temperature (EM)
62	°C		121	30122	10	Room temperature sensor
	°C	10	122	30123	100	Bubble point, high pressure temperature
	°C	10	123	30124	100	Dew point, high pressure temperature
	°C	10	124	30125	100	Dew point, low pressure temperature
	K	10	125	30126	100	Superheat temperature
	K	10	126	30127	100	Sub cooling temperature
	bar(g)	10	127	30128	100	Low pressure side, pressure (bar(g))
	bar(g)	10	128	30129	100	High pressure side, pressure (bar(g))
	°C	10	129	30130	100	Liquid line temperature
	°C	10	130	30131	100	Suction gas temperature
		1	131	30132	1	Heating season integral value
		10	132	30133	100	P - value for gear shifting and demand calculation
		10	133	30134	100	I - value for gear shifting and demand calculation
		10	134	30135	100	D - value for gear shifting and demand calculation
		8	135	30136	100	I - value for compressor ON/OFF (Buffer tank)
		8	136	30137	100	P - value for compressor ON/OFF (Buffer tank)
74	%	5	137	30138	1	Mix valve cooling opening degree (EM2/3)
		2	139	30140	1	Desired gear for tap water
		1	140	30141	1	Desired gear for heating
		5	141	30142	1	Desired gear for cooling
		6	142	30143	1	Desired gear for pool
			143	30144	1	Number of available secondaries Genesis
			144	30145	1	Number of available secondaries Legacy
			145	30146	1	Total distributed gears to all units
			146	30147	1	Maximum gear out of all the currently requested gears
108	°C	7	147	30148	100	Desired temperature distribution circuit Mix valve 1
208	°C	7	148	30149	100	Desired temperature distribution circuit Mix valve 2
208	°C	7	149	30150	100	Desired temperature distribution circuit Mix valve 3
208	°C	7	150	30151	100	Desired temperature distribution circuit Mix valve 4
208	°C	7	151	30152	100	Desired temperature distribution circuit Mix valve 5
184	on/off		152	30153	1	Disconnect hot gas end tank, 0 = connected, 1 = disconnected (EM)
	bit field		153	30154	1	Legacy heat pump compressor running (bit field)
	bit field		154	30155	1	Legacy heat pump reporting alarm (bit field)
	bit field		155	30156	1	Legacy heat pump start signal (bit field)
	bit field		156	30157	1	Legacy heat pump tap water signal (bit field)
	kW		157	30158	100	Current power output of the heat pump unit
	kW		158	30159	100	Current consumed power of the heat pump unit

INPUT REGISTERS - Function codes: 4=read input registers						
Position number	Units	Reference to	Address	De Facto Address	Scale	Description
	bit field		160	30161	1	Primary unit alarm - the combined output of all Class D alarms. This signal is a bit field, one bit for each secondary heat pump unit.
	bit field		161	30162	1	Primary unit alarm - the primary unit has lost communication with one or more Genesis secondaries. This signal is a bit field, one bit for each heat pump.
	bit field		162	30163	1	Primary unit alarm - Class A alarm detected on the Genesis secondary heat pump unit. This signal is a bit field, one bit for each secondary heat pump unit.
	bit field		163	30164	1	Primary unit alarm - Class B alarm detected on the Genesis secondary heat pump unit. This signal is a bit field, one bit for each secondary heat pump unit.
	bit field		170	30171	1	Primary unit alarm - the combined output of all Class E alarms. This signal is a bit field, one bit for each legacy secondary heat pump unit.
	bit field		171	30172	1	Primary unit alarm - general legacy heat pump alarm. This signal is a bit field, one bit for each legacy secondary heat pump unit. Detects if the sum alarm of the secondary unit is active.
	bit field		173	30174	1	Primary unit alarm - the primary unit can not communicate with the corresponding expansion card for the legacy heat pump. This signal is a bit field, one bit for each legacy secondary heat pump unit.
			311	30312	1	Control software version: Major
			312	30313	1	Control software version: Minor
			313	30314	1	Control software version: Micro
	%		315	30316	100	Expansion valve opening degree
	°C		319	30320	1	Inverter temperature
	enum	11	413	30414	1	Ventilation test status *8. Only for Mega E.
251	%		414	30415	100	Surplus heat mixing valve position (EM)
208	RH%		422	30423	100	Distribution circuit 2 humidity, requires room sensor for mixing valve 2 (EM3 only)
208	RH%		423	30424	100	Distribution circuit 3 humidity, requires room sensor for mixing valve 3 (EM3 only)
208	RH%		424	30425	100	Distribution circuit 4 humidity, requires room sensor for mixing valve 4 (EM3 only)
208	RH%		425	30426	100	Distribution circuit 5 humidity, requires room sensor for mixing valve 5 (EM3 only)

### 3.4 Read/Write Analog Registers

HOLDING REGISTERS - Function codes: 3=read holding registers, 6=write single register, 16=write multiple registers						
Position number	Units	Reference to	Address	De Facto Address	Scale	Description
	enum		0	40001	1	Operational mode *2
51	°C	1	3	40004	100	Max limitation, set point curve radiator
51	°C	1	4	40005	100	Min limitation, set point curve radiator
	K		5	40006	100	Comfort wheel settings (+20 offset)
51	°C	1	6	40007	100	Set point heat curve, Y-coordinate 1 (highest outdoor temperature)
51	°C	1	7	40008	100	Set point heat curve, Y-coordinate 2
51	°C	1	8	40009	100	Set point heat curve, Y-coordinate 3

HOLDING REGISTERS - Function codes: 3=read holding registers, 6=write single register, 16=write multiple registers						
Position number	Units	Refer-ence to	Address	De Facto Ad-dress	Scale	Description
51	°C	1	9	40010	100	Set point heat curve, Y-coordinate 4
51	°C	1	10	40011	100	Set point heat curve, Y-coordinate 5
51	°C	1	11	40012	100	Set point heat curve, Y-coordinate 6
51	°C	1	12	40013	100	Set point heat curve, Y-coordinate 7 (lowest outdoor temperature)
50	°C	1	16	40017	100	Heating season stop temperature
53/55	°C	2	22	40023	100	Start temperature tap water
53/55	°C	2	23	40024	100	Stop temperature tap water
		1	26	40027	1	Minimum allowed gear in heating *3
		1	27	40028	1	Maximum allowed gear in heating *3
		2	28	40029	1	Maximum allowed gear in tap water *3
		2	29	40030	1	Minimum allowed gear in tap water *3
74	°C	5	30	40031	100	Cooling mix valve set point (EM)
75	°C	3	31	40032	100	TWC mix valve set point (EM)
54	%	4	32	40033	100	WCS return line set point (EM)
75	%	3	33	40034	100	TWC mix valve lowest allowed opening degree (EM)
75	%	3	34	40035	100	TWC mix valve highest allowed opening degree (EM)
115	°C	3	35	40036	100	TWC start temperature immersion heater (EM)
115	°C	3	37	40038	100	TWC stop temperature immersion heater (EM)
73	%	4	38	40039	100	WCS mix valve lowest allowed opening degree (EM)
73	%	4	39	40040	100	WCS mix valve highest allowed opening degree (EM)
207	%	7	40	40041	100	Mix valve 2 lowest allowed opening degree (EM)
207	%	7	41	40042	100	Mix valve 2 highest allowed opening degree (EM)
207	%	7	42	40043	100	Mix valve 3 lowest allowed opening degree (EM)
207	%	7	43	40044	100	Mix valve 3 highest allowed opening degree (EM)
207	%	7	44	40045	100	Mix valve 4 lowest allowed opening degree (EM)
207	%	7	45	40046	100	Mix valve 4 highest allowed opening degree (EM)
207	%	7	46	40047	100	Mix valve 5 lowest allowed opening degree (EM)
207	%	7	47	40048	100	Mix valve 5 highest allowed opening degree (EM)
	%	5	48	40049	100	Surplus heat chiller set point (EM)
74	%	5	49	40050	100	Cooling supply line mix valve: Lowest allowed opening degree (EM)
74	%	5	50	40051	100	Cooling supply line mix valve: Highest allowed opening degree (EM)
251	%	5	51	40052	100	Surplus heat opening degree for starting fan 1 (EM)
251	%	5	52	40053	100	Surplus heat opening degree for starting fan 2 (EM)
251	%	5	53	40054	100	Surplus heat opening degree for stopping fan 1 (EM)
251	%	5	54	40055	100	Surplus heat opening degree for stopping fan 2 (EM)
251	%	5	55	40056	100	Surplus heat lowest allowed opening degree (EM)
251	%		56	40057	100	Surplus heat highest allowed opening degree (EM)
183	%	6	58	40059	100	Pool charge set point (EM)
250	%	6	59	40060	100	Pool mix valve lowest allowed opening degree (EM)
250	%	6	60	40061	100	Pool mix valve highest allowed opening degree (EM)
	s	1	61	40062	1	Gear shift delay heating
	s	6	62	40063	1	Gear shift delay pool
	s	5	63	40064	1	Gear shift delay cooling
	°C	10	67	40068	100	Brine in high alarm limit

HOLDING REGISTERS - Function codes: 3=read holding registers, 6=write single register, 16=write multiple registers						
Position number	Units	Reference to	Address	De Facto Address	Scale	Description
	°C	10	68	40069	100	Brine in low alarm limit
	°C	10	69	40070	100	Brine out low alarm limit
	K	10	70	40071	100	Brine max delta limit
34	°C		71	40072	100	Hot gas pump start temperature discharge pipe
34	°C		72	40073	100	Hot gas pump lower stop limit temperature discharge pipe
34	°C		73	40074	100	Hot gas pump upper stop limit temperature discharge pipe
117		1	75	40076	1	External additional heater start (PID sum)
	%	10	76	40077	100	Condenser pump lowest allowed speed (%)
	%	10	77	40078	100	Brine pump lowest allowed speed (%)
117		1	78	40079	100	External additional heater stop (PID sum)
	%	10	79	40080	100	Condenser pump highest allowed speed (%)
	%	10	80	40081	100	Brine pump highest allowed speed (%)
	%	10	81	40082	100	Condenser pump standby speed (%)
	%	10	82	40083	100	Brine pump standby speed (%)
		6	85	40086	1	Minimum allowed gear in pool *3
		6	86	40087	1	Maximum allowed gear in pool *3
		5	87	40088	1	Minimum allowed gear in cooling *3
		5	88	40089	1	Maximum allowed gear in cooling *3
	%	10	89	40090	100	Condenser pump minimum speed in tap water operation
	°C	5	105	40106	100	Start temp for cooling (EM)
	°C	5	106	40107	100	Stop temp for cooling (EM)
108	°C	7	107	40108	100	Min limitation Set point curve radiator Mix valve 1
108	°C	7	108	40109	100	Max limitation Set point curve radiator Mix valve 1
108	°C	7	109	40110	100	Set point curve, Y-coordinate 1 Mix valve 1 (highest outdoor temperature)
108	°C	7	110	40111	100	Set point curve, Y-coordinate 2 Mix valve 1
108	°C	7	111	40112	100	Set point curve, Y-coordinate 3 Mix valve 1
108	°C	7	112	40113	100	Set point curve, Y-coordinate 4 Mix valve 1
108	°C	7	113	40114	100	Set point curve, Y-coordinate 5 Mix valve 1
108	°C	7	114	40115	100	Set point curve, Y-coordinate 6 Mix valve 1
108	°C	7	115	40116	100	Set point curve, Y-coordinate 7 Mix valve 1 (lowest outdoor temperature)
51	°C		116	40117	100	Fixed system supply set point, requires defacto address 42 to be enabled
	enum		117	40118	1	Outdoor temperature source, is an enumeration where 0 = designated PT1000 sensor located on BM-card. 1 = BMS register 40119 (De Facto). When the source is BMS the outdoor temperature alarm is automatically removed when the sensor data is valid. If no valid sensor data is present the heat pump will use its designated PT1000 sensor and if that sensor is missing the heat pump will use 0 degrees C as a fallback value.
	°C		118	40119	100	Outdoor temperature sensor, this register will be the source of the outdoor temperature given that BMS-address 40118 is set to 1. The valid range of the temperature is between -50 to 200 degrees C. If this register is not updated with a new temperature within 12 hours or the value is outside the valid range, the fallback logic will be triggered stated in description of BMS register 40118. This signal is automatically filtered in the heat pump.
	A		119	40120	1	Maximum phase current
	A		120	40121	1	Compressor current hysteresis

HOLDING REGISTERS - Function codes: 3=read holding registers, 6=write single register, 16=write multiple registers						
Position number	Units	Refer-ence to	Address	De Facto Ad-ress	Scale	Description
	K		121	40122	100	External brine pump control - Desired delta temperature (EM)
	%		122	40123	100	External brine pump control - Minimum speed (EM)
	%		123	40124	100	External brine pump control - Maximum speed (EM)
	enum		124	40125	1	Desired Power Consumption Control, control mode. Controlled by BMS, may be overridden by the Digital input for Smart grid. In SG-Ready mode 0=Normal, 1=Load-Up, 2=EVU, 3=Boost. When in PL/LU mode 0=Normal, 1=Power Limit(defacto address 40126), 2=Load-Up, 3=Power Limit(defacto address 40126)
	kW		125	40126	10	Input power limit during Power Limitation (defacto 40125), NOTE: If the power limitation is set too low, the compressor will be unable to run.
208	°C	7	199	40200	100	Min limitation Set point curve radiator Mix valve 2
208	°C	7	200	40201	100	Max limitation Set point curve radiator Mix valve 2
208	°C	7	201	40202	100	Set point curve, Y-coordinate 1 Mix valve 2 (highest outdoor temperature)
208	°C	7	202	40203	100	Set point curve, Y-coordinate 2 Mix valve 2
208	°C	7	203	40204	100	Set point curve, Y-coordinate 3 Mix valve 2
208	°C	7	204	40205	100	Set point curve, Y-coordinate 4 Mix valve 2
208	°C	7	205	40206	100	Set point curve, Y-coordinate 5 Mix valve 2
208	°C	7	206	40207	100	Set point curve, Y-coordinate 6 Mix valve 2
208	°C	7	207	40208	100	Set point curve, Y-coordinate 7 Mix valve 2 (lowest outdoor temperature)
208	°C	7	208	40209	100	Min limitation Set point curve radiator Mix valve 3
208	°C	7	209	40210	100	Max limitation Set point curve radiator Mix valve 3
208	°C	7	210	40211	100	Set point curve, Y-coordinate 1 Mix valve 3 (highest outdoor temperature)
208	°C	7	211	40212	100	Set point curve, Y-coordinate 2 Mix valve 3
208	°C	7	212	40213	100	Set point curve, Y-coordinate 3 Mix valve 3
208	°C	7	213	40214	100	Set point curve, Y-coordinate 4 Mix valve 3
208	°C	7	214	40215	100	Set point curve, Y-coordinate 5 Mix valve 3
208	°C	7	215	40216	100	Set point curve, Y-coordinate 6 Mix valve 3
208	°C	7	216	40217	100	Set point curve, Y-coordinate 7 Mix valve 3 (lowest outdoor temperature)
208	°C	7	239	40240	100	Min limitation Set point curve radiator Mix valve 4
208	°C	7	240	40241	100	Max limitation Set point curve radiator Mix valve 4
208	°C	7	241	40242	100	Set point curve, Y-coordinate 1 Mix valve 4 (highest outdoor temperature)
208	°C	7	242	40243	100	Set point curve, Y-coordinate 2 Mix valve 4
208	°C	7	243	40244	100	Set point curve, Y-coordinate 3 Mix valve 4
208	°C	7	244	40245	100	Set point curve, Y-coordinate 4 Mix valve 4
208	°C	7	245	40246	100	Set point curve, Y-coordinate 5 Mix valve 4
208	°C	7	246	40247	100	Set point curve, Y-coordinate 6 Mix valve 4
208	°C	7	247	40248	100	Set point curve, Y-coordinate 7 Mix valve 4 (lowest outdoor temperature)
208	°C	7	248	40249	100	Min limitation Set point curve radiator Mix valve 5
208	°C	7	249	40250	100	Max limitation Set point curve radiator Mix valve 5
208	°C	7	250	40251	100	Set point curve, Y-coordinate 1 Mix valve 5 (highest outdoor temperature)
208	°C	7	251	40252	100	Set point curve, Y-coordinate 2 Mix valve 5

HOLDING REGISTERS - Function codes: 3=read holding registers, 6=write single register, 16=write multiple registers						
Position number	Units	Reference to	Address	De Facto Address	Scale	Description
208	°C	7	252	40253	100	Set point curve, Y-coordinate 3 Mix valve 5
208	°C	7	253	40254	100	Set point curve, Y-coordinate 4 Mix valve 5
208	°C	7	254	40255	100	Set point curve, Y-coordinate 5 Mix valve 5
208	°C	7	255	40256	100	Set point curve, Y-coordinate 6 Mix valve 5
208	°C	7	256	40257	100	Set point curve, Y-coordinate 7 Mix valve 5 (lowest outdoor temperature)
108	enum		298	40299	1	Selected mode for mixing valve 1, 0:Heat, 1:Cool, 2:Auto
	°C	6	299	40300	10	Set point return temp from pool to heat exchanger (EM)
		6	300	40301	10	Set point pool hysteresis (EM)
108	°C	5	302	40303	100	Set point for supply line temp passive cooling with mixing valve 1
	°C	5	303	40304	100	Set point minimum outdoor temp when cooling is permitted
	°C	1	304	40305	100	External heater outdoor temp limit
	enum		305	40306	1	Selected mode for mixing valve 2, 0:Heat, 1:Cool, 2:Auto (EM3 only)
208	°C	5	306	40307	100	Desired cooling temperature setpoint mixing valve 2 (EM3 only)
	°C	5	307	40308	100	Seasonal cooling temperature (outdoor temp.), mixing valve 2 (EM3 only)
	°C	7	308	40309	100	Seasonal heating temperature (outdoor temp.), mixing valve 2 (EM3 only)
	enum		309	40310	1	Selected mode for mixing valve 3, 0:Heat, 1:Cool, 2:Auto (EM3 only)
208	°C	5	310	40311	100	Desired cooling temperature setpoint mixing valve 3 (EM3 only)
	°C	5	311	40312	100	Seasonal cooling temperature (outdoor temp.), mixing valve 3 (EM3 only)
	°C	7	312	40313	100	Seasonal heating temperature (outdoor temp.), mixing valve 3 (EM3 only)
	enum		313	40314	1	Selected mode for mixing valve 4, 0:Heat, 1:Cool, 2:Auto (EM3 only)
208	°C	5	314	40315	100	Desired cooling temperature setpoint mixing valve 4 (EM3 only)
	°C	5	315	40316	100	Seasonal cooling temperature (outdoor temp.), mixing valve 4 (EM3 only)
	°C	7	316	40317	100	Seasonal heating temperature (outdoor temp.), mixing valve 4 (EM3 only)
	enum		317	40318	1	Selected mode for mixing valve 5, 0:Heat, 1:Cool, 2:Auto (EM3 only)
208	°C	5	318	40319	100	Desired cooling temperature setpoint mixing valve 5 (EM3 only)
	°C	5	319	40320	100	Seasonal cooling temperature (outdoor temp.), mixing valve 5 (EM3 only)
	°C	7	320	40321	100	Seasonal heating temperature (outdoor temp.), mixing valve 5 (EM3 only)
317	enum		321	40322	1	Enabled immersion heater, Mega S-E only *7
208	°C		322	40323	100	Distribution circuit 2 desired room temperature setpoint
208	°C		323	40324	100	Distribution circuit 3 desired room temperature setpoint
208	°C		324	40325	100	Distribution circuit 4 desired room temperature setpoint
208	°C		325	40326	100	Distribution circuit 5 desired room temperature setpoint

## 4 Heat pump unit

### 4.1 Heat pump unit

Position number	Units	Reference to	Address	De Facto Address	Scale	Description
	on/off		3	4	1	Reset all alarms
117	on/off	1	5	6	1	Enable external additional heater
71	on/off		7	8	1	Enable flow switch/pressure switch
	on/off	2	8	9	1	Enable tap water
	on/off	1	9	10	1	Enable heat
	on/off	10	20	21	1	Enable brine out monitoring
	on/off	10	21	22	1	Enable brine pump continuous operation
36	on/off	1	22	23	1	Enable system circulation pump
117	on/off	1	25	26	100	Enable additional heater only (No compressor). Requires Operation mode: Standby
	on/off	10	34	35	1	Enable variable speed mode for condenser pump
117	on/off	10	35	36	1	Enable variable speed mode for brine pump
	on/off		39	40	1	Enable outdoor temp dependent for external heater
	on/off	10	42	43	1	Enable evaporator freeze protection
	on/off		59	60	1	Enable continuous operation mode for condenser pump.
	on/off		60	61	1	Allow current limiter to restrict external additional heater
	on/off		61	62	1	Allow current limiter to restrict secondary heat pump units
	on/off		63	64	1	External brine pump control - Enable delta control (EM)
	on/off		64	65	1	External brine pump control - Intermediate heat exchanger (EM)
	active/inactive		0	10001	1	Alarm active, Class: A
	active/inactive		1	10002	1	Alarm active, Class: B
	active/inactive		2	10003	1	Alarm active, Class: C
	active/inactive		3	10004	1	Alarm active, Class: D - Genesis secondary
	active/inactive		4	10005	1	Alarm active, Class: E - Legacy secondary
	active/inactive	10	9	10010	1	High pressure switch alarm
	active/inactive	10	10	10011	1	Low pressure level alarm
	active/inactive	10	11	10012	1	High discharge pipe temperature alarm
	on/off	10	12	10013	1	Operating pressure limit indication
	active/inactive	10	13	10014	1	Discharge pipe sensor alarm
	active/inactive	10	14	10015	1	Liquid line sensor alarm
	active/inactive	10	15	10016	1	Suction gas sensor alarm

Position number	Units	Reference to	Address	De Facto Address	Scale	Description
71	active/ inactive		16	10017	1	Flow/pressure switch alarm
	active/ inactive		22	10023	1	Power input phase detection alarm
	active/ inactive	10	23	10024	1	Inverter unit alarm
	active/ inactive	10	25	10026	1	Compressor low speed alarm
	active/ inactive	10	26	10027	1	Low super heat alarm
	active/ inactive	10	27	10028	1	Pressure ratio out of range alarm
	active/ inactive		28	10029	1	Compressor pressure outside envelope alarm
	active/ inactive	10	29	10030	1	Brine temperature out of range alarm
	active/ inactive	10	30	10031	1	Brine in sensor alarm
	active/ inactive	10	31	10032	1	Brine out sensor alarm
	active/ inactive	10	32	10033	1	Condenser in sensor alarm
	active/ inactive	10	33	10034	1	Condenser out sensor alarm
50	active/ inactive		34	10035	1	Outdoor sensor alarm
	active/ inactive		49	10050	1	Brine delta out of range alarm
	active/ inactive		56	10057	1	Brine in low temperature alarm
	active/ inactive	10	57	10058	1	Brine out low temperature alarm
	active/ inactive		66	10067	1	Sum alarm
	active/ inactive	10	75	10076	1	Inverter unit communication alarm
	on/off		79	10080	1	External relay for brine/ground water pump.
180	active/ inactive	3	81	10082	1	Tap water end tank sensor alarm
	active/ inactive		83	10084	1	Genesis secondary unit alarm - this specific secondary unit can't communicate with its primary unit
	active/ inactive		84	10085	1	Primary unit alarm - the primary has detected other primary units on the same network with a network mask that is allowing conflict. Change network settings in order to avoid problem. For instance change port number on the primary and its secondary unit.
	active/ inactive		85	10086	1	Primary unit alarm - the primary has not detected all secondary units. Make sure that the primary/secondary settings are correct and the network mask and port and number of Genesis secondaries settings are correct.
	on/off	10	86	10087	1	Oil boost in progress
	active/ inactive		87	10088	1	Tap water top sensor alarm.
	on/off	10	199	10200	1	Compressor control signal
	on/off		201	10202	1	Smart Grid 1, EVU input

Position number	Units	Reference to	Address	De Facto Address	Scale	Description
	on/off		202	10203	1	External alarm input
	on/off		204	10205	1	Smart Grid 2
117	on/off		206	10207	1	External additional heater control signal
	on/off	10	210	10211	1	Condenser pump On/off control
	on/off	10	218	10219	1	Brine pump On/off control
	on/off	1	219	10220	1	External heater circulation pump control signal
117	on/off	1	221	10222	1	External additional heater active
	on/off	10	224	10225	1	Heat pump stopping
	on/off	10	225	10226	1	Heat pump OK to start
	on/off	10	246	10247	1	Compressor is unable to speed up
	yes/no		274	10275	1	Compressor allowed to run status
		10	4	30005	100	Compressor available gears *3
	rpm	10	5	30006	1	Compressor speed RPM
117	%	1	6	30007	100	External additional heater: Current demand (%)
	°C	10	7	30008	100	Discharge pipe temperature
	°C	10	8	30009	100	Condenser in temperature
	°C	10	9	30010	100	Condenser out temperature
	°C	10	10	30011	100	Brine in temperature
	°C	10	11	30012	100	Brine out temperature
50	°C		13	30014	100	Outdoor temperature
48	°C		31	30032	100	External brine pump control - Brine in temperature (EM)
49	°C		32	30033	100	External brine pump control - Brine out temperature (EM)
172	%		33	30034	100	External brine pump control - Pump speed in percent (EM)
		5	36	30037	1	Cooling season integral value
	%	10	39	30040	100	Condenser circulation pump speed (%)
	%	10	44	30045	100	Brine circulation pump speed (%)
	h	10	48	30049	1	Compressor operating hours (MSB)
	h	10	49	30050	1	Compressor operating hours (LSB)
117	h	1	52	30053	1	External additional heater operating hours (MSB)
117	h	1	53	30054	1	External additional heater operating hours (LSB)
	%	10	54	30055	100	Compressor speed percent
	enum		55	30056	1	Currently running: Second prioritised demand *1
	enum		56	30057	1	Currently running: Third prioritised demand *1
			57	30058	1	Software version: Major
			58	30059	1	Software version: Minor
			59	30060	1	Software version: Micro
	s	10	60	30061	1	Compressor temporarily blocked, (start restriction timer)
		10	61	30062	100	Compressor current gear
	enum		62	30063	1	Queued demand, first priority *1
	enum		63	30064	1	Queued demand, second priority *1
	enum		64	30065	1	Queued demand, third priority *1
	enum		65	30066	1	Queued demand, fourth priority *1
	enum		66	30067	1	Queued demand, fifth priority *1
317	step		67	30068	1	Active step internal immersion heater, Mega S-E
	enum		82	30083	1	Comfort mode *4
62	°C		121	30122	10	Room temperature sensor

Position number	Units	Reference to	Address	De Facto Address	Scale	Description
	°C	10	122	30123	100	Bubble point, high pressure temperature
	°C	10	123	30124	100	Dew point, high pressure temperature
	°C	10	124	30125	100	Dew point, low pressure temperature
	K	10	125	30126	100	Superheat temperature
	K	10	126	30127	100	Sub cooling temperature
	bar(g)	10	127	30128	100	Low pressure side, pressure (bar(g))
	bar(g)	10	128	30129	100	High pressure side, pressure (bar(g))
	°C	10	129	30130	100	Liquid line temperature
	°C	10	130	30131	100	Suction gas temperature
		1	131	30132	1	Heating season integral value
			132	30133	100	P - value for gear shifting and demand calculation
			133	30134	100	I - value for gear shifting and demand calculation
			134	30135	100	D - value for gear shifting and demand calculation
		8	135	30136	100	I - value for compressor ON/OFF (Buffer tank)
		8	136	30137	100	P - value for compressor ON/OFF (Buffer tank)
			143	30144	1	Number of available secondaries Genesis
			144	30145	1	Number of available secondaries Legacy
			145	30146	1	Total distributed gears to all units
			146	30147	1	Maximum gear out of all the currently requested gears
	bit field		153	30154	1	Legacy heat pump compressor running (bit field)
	bit field		154	30155	1	Legacy heat pump reporting alarm (bit field)
	bit field		155	30156	1	Legacy heat pump start signal (bit field)
	bit field		156	30157	1	Legacy heat pump tap water signal (bit field)
	kW		157	30158	100	Current power output of the heat pump unit
	kW		158	30159	100	Current consumed power of the heat pump unit
	bit field		160	30161	1	Primary unit alarm - the combined output of all Class D alarms. This signal is a bit field, one bit for each secondary heat pump unit.
	bit field		161	30162	1	Primary unit alarm - the primary unit has lost communication with one or more Genesis secondaries. This signal is a bit field, one bit for each heat pump.
	bit field		162	30163	1	Primary unit alarm - Class A alarm detected on the Genesis secondary heat pump unit. This signal is a bit field, one bit for each secondary heat pump unit.
	bit field		163	30164	1	Primary unit alarm - Class B alarm detected on the Genesis secondary heat pump unit. This signal is a bit field, one bit for each secondary heat pump unit.
	bit field		170	30171	1	Primary unit alarm - the combined output of all Class E alarms. This signal is a bit field, one bit for each legacy secondary heat pump unit.
	bit field		171	30172	1	Primary unit alarm - general legacy heat pump alarm. This signal is a bit field, one bit for each legacy secondary heat pump unit. Detects if the sum alarm of the secondary unit is active.
	bit field		173	30174	1	Primary unit alarm - the primary unit can not communicate with the corresponding expansion card for the legacy heat pump. This signal is a bit field, one bit for each legacy secondary heat pump unit.
			311	30312	1	Control software version: Major
			312	30313	1	Control software version: Minor
			313	30314	1	Control software version: Micro
	%		315	30316	100	Expansion valve opening degree

Position number	Units	Reference to	Address	De Facto Address	Scale	Description
	°C		319	30320	1	Inverter temperature
		1	26	40027	1	Minimum allowed gear in heating *3
		1	27	40028	1	Maximum allowed gear in heating *3
		2	28	40029	1	Maximum allowed gear in tap water *3
		2	29	40030	1	Minimum allowed gear in tap water *3
	s	1	61	40062	1	Gear shift delay heating
	s	6	62	40063	1	Gear shift delay pool
	s	5	63	40064	1	Gear shift delay cooling
	°C	10	67	40068	100	Brine in high alarm limit
	°C	10	68	40069	100	Brine in low alarm limit
	°C	10	69	40070	100	Brine out low alarm limit
	K	10	70	40071	100	Brine max delta limit
34	°C		71	40072	100	Hot gas pump start temperature discharge pipe
34	°C		72	40073	100	Hot gas pump lower stop limit temperature discharge pipe
34	°C		73	40074	100	Hot gas pump upper stop limit temperature discharge pipe
117		1	75	40076	1	External additional heater start (PID sum)
	%	10	76	40077	100	Condenser pump lowest allowed speed (%)
	%	10	77	40078	100	Brine pump lowest allowed speed (%)
117		1	78	40079	100	External additional heater stop (PID sum)
	%	10	79	40080	100	Condenser pump highest allowed speed (%)
	%	10	80	40081	100	Brine pump highest allowed speed (%)
	%	10	81	40082	100	Condenser pump standby speed (%)
	%	10	82	40083	100	Brine pump standby speed (%)
		6	85	40086	1	Minimum allowed gear in pool *3
		6	86	40087	1	Maximum allowed gear in pool *3
		5	87	40088	1	Minimum allowed gear in cooling *3
		5	88	40089	1	Maximum allowed gear in cooling *3
	enum		117	40118	1	Outdoor temperature source, is an enumeration where 0 = designated PT1000 sensor located on BM-card. 1 = BMS register 40119 (De Facto). When the source is BMS the outdoor temperature alarm is automatically removed when the sensor data is valid. If no valid sensor data is present the heat pump will use its designated PT1000 sensor and if that sensor is missing the heat pump will use 0 degrees C as a fallback value.
	°C		118	40119	100	Outdoor temperature sensor, this register will be the source of the outdoor temperature given that BMS-address 40118 is set to 1. The valid range of the temperature is between -50 to 200 degrees C. If this register is not updated with a new temperature within 12 hours or the value is outside the valid range, the fallback logic will be triggered stated in description of BMS register 40118. This signal is automatically filtered in the heat pump.
	A		119	40120	1	Maximum phase current
	A		120	40121	1	Compressor current hysteresis
	K		121	40122	100	External brine pump control - Desired delta temperature (EM)
	%		122	40123	100	External brine pump control - Minimum speed (EM)
	%		123	40124	100	External brine pump control - Maximum speed (EM)

Position number	Units	Reference to	Address	De Facto Address	Scale	Description
	enum		124	40125	1	Desired Power Consumption Control, control mode. Controlled by BMS, may be overridden by the Digital input for Smart grid. In SG-Ready mode 0=Normal, 1=Load-Up, 2=EVU,3=Boost. When in PL/LU mode 0=Normal, 1=Power Limit(defacto address 40126), 2=Load-Up, 3=Power Limit(defacto address 40126)
	kW		125	40126	10	Input power limit during Power Limitation (defacto 40125), NOTE: If the power limitation is set too low, the compressor will be unable to run.
	°C	1	304	40305	100	External heater outdoor temp limit
317	enum		321	40322	1	Enabled immersion heater, Mega S-E only *7

## 5 Heat

### 5.1 Heating system

Position number	Units	Reference to	Address	De Facto Address	Scale	Description
			41	42	1	Enable fixed system supply set point, allows defacto address 40117
51	active/inactive	1	24	10025	1	System supply low temperature alarm
51	active/inactive	1	35	10036	1	System supply line sensor alarm
62	active/inactive		74	10075	1	Temperature room sensor alarm
36	on/off	1	211	10212	1	System circulation pump control signal
	active/inactive	1	220	10221	1	Heating season (winter) active
51	°C	1	12	30013	100	System supply line temperature
51	°C	1	18	30019	100	System supply line calculated set point
51	°C	1	19	30020	100	Selected heat curve, (system) supply line
50	°C	1	20	30021	100	Heat curve, X-coordinate 1 (highest outdoor temperature)
50	°C	1	21	30022	100	Heat curve, X-coordinate 2
50	°C	1	22	30023	100	Heat curve, X-coordinate 3
50	°C	1	23	30024	100	Heat curve, X-coordinate 4
50	°C	1	24	30025	100	Heat curve, X-coordinate 5
50	°C	1	25	30026	100	Heat curve, X-coordinate 6
50	°C	1	26	30027	100	Heat curve, X-coordinate 7 (lowest outdoor temperature)
	°C		27	30028	100	System return line temperature.
		10	30	30031	100	Calculated demand (heat)
	°C	8	41	30042	100	Buffer tank temperature
	°C	8	68	30069	100	Buffer tank charge set point
		1	140	30141	1	Desired gear for heating
51	°C	1	3	40004	100	Max limitation, set point curve radiator
51	°C	1	4	40005	100	Min limitation, set point curve radiator
	K	1	5	40006	100	Comfort wheel settings (+20 offset)
51	°C	1	6	40007	100	Set point heat curve, Y-coordinate 1 (highest outdoor temperature)
51	°C	1	7	40008	100	Set point heat curve, Y-coordinate 2
51	°C	1	8	40009	100	Set point heat curve, Y-coordinate 3
51	°C	1	9	40010	100	Set point heat curve, Y-coordinate 4
51	°C	1	10	40011	100	Set point heat curve, Y-coordinate 5
51	°C	1	11	40012	100	Set point heat curve, Y-coordinate 6
51	°C	1	12	40013	100	Set point heat curve, Y-coordinate 7 (lowest outdoor temperature)
	°C	1	16	40017	100	Heating season stop temperature
51	°C		116	40117	100	Fixed system supply set point, requires defacto address 42 to be enabled

## 5.2 Mix valve 1

Position number	Units	Reference to	Address	De Facto Address	Scale	Description
107	on/off	7	11	12	1	Enable mix valve 1
107	on/off	5	37	38	1	Enable outdoor temp dependent for cooling with mixing valve 1
	on/off	5	38	39	1	Enable internal brine pump to start when cooling is active for mixing valve 1
108	active/inactive	7	36	10037	1	Mix valve 1 supply line sensor alarm
108	active/inactive	7	60	10061	1	Mix valve 1 supply temperature deviation alarm
109	on/off	7	209	10210	1	Mix valve 1 circulation pump control signal
107	on/off	5	245	10246	1	Indication when mixing valve 1 is producing passive cooling
108	°C	7	40	30041	100	Mix valve 1 supply line temperature
107	%	7	43	30044	100	Mix valve 1 position
108	°C	7	147	30148	100	Desired temperature distribution circuit Mix valve 1
108	°C	7	107	40108	100	Min limitation Set point curve radiator Mix valve 1
108	°C	7	108	40109	100	Max limitation Set point curve radiator Mix valve 1
108	°C	7	109	40110	100	Set point curve, Y-coordinate 1 Mix valve 1 (highest outdoor temperature)
108	°C	7	110	40111	100	Set point curve, Y-coordinate 2 Mix valve 1
108	°C	7	111	40112	100	Set point curve, Y-coordinate 3 Mix valve 1
108	°C	7	112	40113	100	Set point curve, Y-coordinate 4 Mix valve 1
108	°C	7	113	40114	100	Set point curve, Y-coordinate 5 Mix valve 1
108	°C	7	114	40115	100	Set point curve, Y-coordinate 6 Mix valve 1
108	°C	7	115	40116	100	Set point curve, Y-coordinate 7 Mix valve 1 (lowest outdoor temperature)
108	enum		298	40299	1	Selected mode for mixing valve 1, 0:Heat, 1:Cool, 2:Auto
108	°C	5	302	40303	100	Set point for supply line temp passive cooling with mixing valve 1
	°C	5	303	40304	100	Set point minimum outdoor temp when cooling is permitted

## 5.3 Mix valve 2

Position number	Units	Reference to	Address	De Facto Address	Scale	Description
207	on/off	7	16	17	1	Enable mix valve 2 (EM)
208	active/inactive	7	37	10038	1	Mix valve 2 supply line sensor alarm (EM)
208	active/inactive	7	61	10062	1	Mix valve 2 supply temperature deviation alarm (EM)
	on/off		270	10271	1	Distribution circuit 2 pump control signal (EM)
207	%	7	87	30088	100	Mix valve 2 position (EM)
208	°C	7	99	30100	100	Mix valve 2 supply line temperature (EM)
210	°C	7	109	30110	100	Mix valve 2 return line temperature (EM)
	°C	7	110	30111	100	Mix valve 2 room temperature, requires room sensor for mixing valve 2 (EM3 only)
208	°C	7	148	30149	100	Desired temperature distribution circuit Mix valve 2
208	RH%		422	30423	100	Distribution circuit 2 humidity, requires room sensor for mixing valve 2 (EM3 only)

Position number	Units	Reference to	Address	De Facto Address	Scale	Description
207	%	7	40	40041	100	Mix valve 2 lowest allowed opening degree (EM)
207	%	7	41	40042	100	Mix valve 2 highest allowed opening degree (EM)
208	°C	7	199	40200	100	Min limitation Set point curve radiator Mix valve 2
208	°C	7	200	40201	100	Max limitation Set point curve radiator Mix valve 2
208	°C	7	201	40202	100	Set point curve, Y-coordinate 1 Mix valve 2 (highest outdoor temperature)
208	°C	7	202	40203	100	Set point curve, Y-coordinate 2 Mix valve 2
208	°C	7	203	40204	100	Set point curve, Y-coordinate 3 Mix valve 2
208	°C	7	204	40205	100	Set point curve, Y-coordinate 4 Mix valve 2
208	°C	7	205	40206	100	Set point curve, Y-coordinate 5 Mix valve 2
208	°C	7	206	40207	100	Set point curve, Y-coordinate 6 Mix valve 2
208	°C	7	207	40208	100	Set point curve, Y-coordinate 7 Mix valve 2 (lowest outdoor temperature)
	enum	7	305	40306	1	Selected mode for mixing valve 2, 0:Heat, 1:Cool, 2:Auto (EM3 only)
208	°C	7	306	40307	100	Desired cooling temperature setpoint mixing valve 2 (EM3 only)
207	°C	5	307	40308	100	Seasonal cooling temperature (outdoor temp.), mixing valve 2 (EM3 only)
207	°C	5	308	40309	100	Seasonal heating temperature (outdoor temp.), mixing valve 2 (EM3 only)
208	°C		322	40323	100	Distribution circuit 2 desired room temperature setpoint
207	on/off	5	43	44	1	Enable outdoor temp dependent for cooling with mixing valve 2 (EM3 only)*5
207	on/off	5	44	45	1	Enable dew point calculation on mixing valve 2, requires room sensor for mixing valve 2 (EM3 only)
207	on/off	7	45	46	1	Enable outdoor temp dependent for heating with mixing valve 2 (EM3 only)*5
	on/off	5	55	56	1	Enable internal brine pump to start when cooling is active for mixing valve 2 (EM3 only)

## 5.4 Mix valve 3

Position number	Units	Reference to	Address	De Facto Address	Scale	Description
207	on/off	7	17	18	1	Enable mix valve 3 (EM)
208	active/inactive	7	38	10039	1	Mix valve 3 supply line sensor alarm (EM)
208	active/inactive	7	62	10063	1	Mix valve 3 supply temperature deviation alarm (EM)
	on/off		271	10272	1	Distribution circuit 3 pump control signal (EM)
207	%	7	88	30089	100	Mix valve 3 position (EM)
208	°C	7	100	30101	100	Mix valve 3 supply line temperature (EM)
210	°C	7	111	30112	100	Mix valve 3 return line temperature (EM)
	°C	7	112	30113	100	Mix valve 3 room temperature, requires room sensor for mixing valve 3 (EM3 only)
208	°C	7	149	30150	100	Desired temperature distribution circuit Mix valve 3
208	RH%		423	30424	100	Distribution circuit 3 humidity, requires room sensor for mixing valve 3 (EM3 only)
207	%	7	42	40043	100	Mix valve 3 lowest allowed opening degree (EM)
207	%	7	43	40044	100	Mix valve 3 highest allowed opening degree (EM)
208	°C	7	208	40209	100	Min limitation Set point curve radiator Mix valve 3

Position number	Units	Reference to	Address	De Facto Address	Scale	Description
208	°C	7	209	40210	100	Max limitation Set point curve radiator Mix valve 3
208	°C	7	210	40211	100	Set point curve, Y-coordinate 1 Mix valve 3 (highest outdoor temperature)
208	°C	7	211	40212	100	Set point curve, Y-coordinate 2 Mix valve 3
208	°C	7	212	40213	100	Set point curve, Y-coordinate 3 Mix valve 3
208	°C	7	213	40214	100	Set point curve, Y-coordinate 4 Mix valve 3
208	°C	7	214	40215	100	Set point curve, Y-coordinate 5 Mix valve 3
208	°C	7	215	40216	100	Set point curve, Y-coordinate 6 Mix valve 3
208	°C		216	40217	100	Set point curve, Y-coordinate 7 Mix valve 3 (lowest outdoor temperature)
			309	40310	1	Selected mode for mixing valve 3, 0:Heat, 1:Cool, 2:Auto (EM3 only)
208	°C	5	310	40311	100	Desired cooling temperature setpoint mixing valve 3 (EM3 only)
208	°C	5	311	40312	100	Seasonal cooling temperature (outdoor temp.), mixing valve 3 (EM3 only)
208	°C	7	312	40313	100	Seasonal heating temperature (outdoor temp.), mixing valve 3 (EM3 only)
208	°C		323	40324	100	Distribution circuit 3 desired room temperature setpoint
207	on/off	5	46	47	1	Enable outdoor temp dependent for cooling with mixing valve 3 (EM3 only)*5
207	on/off	5	47	48	1	Enable dew point calculation on mixing valve 3, requires room sensor for mixing valve 3 (EM3 only)
207	on/off	7	48	49	1	Enable outdoor temp dependent for heating with mixing valve 3 (EM3 only)*5
	on/off	5	56	57	1	Enable internal brine pump to start when cooling is active for mixing valve 3 (EM3 only)

## 5.5 Mix valve 4

Position number	Units	Reference to	Address	De Facto Address	Scale	Description
207	on/off	7	18	19	1	Enable mix valve 4 (EM)
208	active/inactive	7	39	10040	1	Mix valve 4 supply line sensor alarm (EM)
208	active/inactive	7	63	10064	1	Mix valve 4 supply temperature deviation alarm (EM)
	on/off		272	10273	1	Distribution circuit 4 pump control signal (EM)
207	%	7	89	30090	100	Mix valve 4 position (EM)
208	°C	7	101	30102	100	Mix valve 4 supply line temperature (EM)
210	°C	7	113	30114	100	Mix valve 4 return line temperature (EM)
	°C	7	114	30115	100	Mix valve 4 room temperature, requires room sensor for mixing valve 4 (EM3 only)
208	°C	7	150	30151	100	Desired temperature distribution circuit Mix valve 4
208	RH%		424	30425	100	Distribution circuit 4 humidity, requires room sensor for mixing valve 4 (EM3 only)
207		7	44	40045	100	Mix valve 4 lowest allowed opening degree (EM)
207		7	45	40046	100	Mix valve 4 highest allowed opening degree (EM)
208	°C	7	239	40240	100	Min limitation Set point curve radiator Mix valve 4
208	°C	7	240	40241	100	Max limitation Set point curve radiator Mix valve 4

Position number	Units	Reference to	Address	De Facto Address	Scale	Description
208	°C	7	241	40242	100	Set point curve, Y-coordinate 1 Mix valve 4 (highest outdoor temperature)
208	°C	7	242	40243	100	Set point curve, Y-coordinate 2 Mix valve 4
208	°C	7	243	40244	100	Set point curve, Y-coordinate 3 Mix valve 4
208	°C	7	244	40245	100	Set point curve, Y-coordinate 4 Mix valve 4
208	°C	7	245	40246	100	Set point curve, Y-coordinate 5 Mix valve 4
208	°C	7	246	40247	100	Set point curve, Y-coordinate 6 Mix valve 4
208	°C	7	247	40248	100	Set point curve, Y-coordinate 7 Mix valve 4 (lowest outdoor temperature)
	enum		313	40314	1	Selected mode for mixing valve 4, 0:Heat, 1:Cool, 2:Auto (EM3 only)
208	°C	5	314	40315	100	Desired cooling temperature setpoint mixing valve 4 (EM3 only)
208	°C	5	315	40316	100	Seasonal cooling temperature (outdoor temp.), mixing valve 4 (EM3 only)
208	°C	7	314	40317	100	Seasonal heating temperature (outdoor temp.), mixing valve 4 (EM3 only)
208	°C		324	40325	100	Distribution circuit 4 desired room temperature setpoint
207	on/off	5	49	50	1	Enable outdoor temp dependent for cooling with mixing valve 4 (EM3 only)*5
207	on/off	5	50	51	1	Enable dew point calculation on mixing valve 4, requires room sensor for mixing valve 4 (EM3 only)
207	on/off	7	51	52	1	Enable outdoor temp dependent for heating with mixing valve 4 (EM3 only)*5
		5	57	58	1	Enable internal brine pump to start when cooling is active for mixing valve 4 (EM3 only)

## 5.6 Mix valve 5

Position number	Units	Reference to	Address	De Facto Address	Scale	Description
207	on/off	7	19	20	1	Enable mix valve 5 (EM)
208	active/inactive	7	40	10041	1	Mix valve 5 supply line sensor alarm (EM)
208	active/inactive	7	64	10065	1	Mix valve 5 supply temperature deviation alarm (EM)
	on/off		273	10274	1	Distribution circuit 5 pump control signal (EM)
207	%	7	90	30091	100	Mix valve 5 position (EM)
208	°C	7	107	30108	100	Mix valve 5 supply line temperature (EM)
210	°C	7	115	30116	100	Mix valve 5 return line temperature (EM)
	°C	7	116	30117	100	Mix valve 5 room temperature, requires room sensor for mixing valve 5 (EM3 only)
208	°C	7	151	30152	100	Desired temperature distribution circuit Mix valve 5
208	RH%		425	30426	100	Distribution circuit 5 humidity, requires room sensor for mixing valve 5 (EM3 only)
207	%	7	46	40047	100	Mix valve 5 lowest allowed opening degree (EM)
207	%	7	47	40048	100	Mix valve 5 highest allowed opening degree (EM)
208	°C	7	248	40249	100	Min limitation Set point curve radiator Mix valve 5
208	°C	7	249	40250	100	Max limitation Set point curve radiator Mix valve 5
208	°C	7	250	40251	100	Set point curve, Y-coordinate 1 Mix valve 5 (highest outdoor temperature)

Position number	Units	Reference to	Address	De Facto Address	Scale	Description
208	°C	7	251	40252	100	Set point curve, Y-coordinate 2 Mix valve 5
208	°C	7	252	40253	100	Set point curve, Y-coordinate 3 Mix valve 5
208	°C	7	253	40254	100	Set point curve, Y-coordinate 4 Mix valve 5
208	°C	7	254	40255	100	Set point curve, Y-coordinate 5 Mix valve 5
208	°C	7	255	40256	100	Set point curve, Y-coordinate 6 Mix valve 5
208	°C	7	256	40257	100	Set point curve, Y-coordinate 7 Mix valve 5 (lowest outdoor temperature)
	enum		317	40318	1	Selected mode for mixing valve 5, 0:Heat, 1:Cool, 2:Auto (EM3 only)
208	°C	5	318	40319	100	Desired cooling temperature setpoint mixing valve 5 (EM3 only)
208	°C	5	319	40320	100	Seasonal cooling temperature (outdoor temp.), mixing valve 5 (EM3 only)
208	°C	7	320	40321	100	Seasonal heating temperature (outdoor temp.), mixing valve 5 (EM3 only)
208	°C		325	40326	100	Distribution circuit 5 desired room temperature setpoint3
207	on/off	5	52	53	1	Enable outdoor temp dependent for cooling with mixing valve 5 (EM3 only)*5
207	on/off	5	51	54	1	Enable dew point calculation on mixing valve 5, requires room sensor for mixing valve 5 (EM3 only)
207	on/off	7	50	55	1	Enable outdoor temp dependent for heating with mixing valve 5 (EM3 only)*5
	on/off	5	58	59	1	Enable internal brine pump to start when cooling is active for mixing valve 5 (EM3 only)

## 6 Tap water

### 6.1 Tap water

Position number	Units	Reference to	Address	De Facto Address	Scale	Description
34	on/off		14	15	1	Enable hot gas pump
53	active/inactive	2	50	10051	1	Tap water mid sensor alarm
34	on/off		213	10214	1	Hot gas circulation pump control signal
55	°C	2	15	30016	100	Tap water top temperature
53	°C	2	16	30017	100	Tap water lower temperature
53/55	°C	2	17	30018	100	Tap water weighted temperature
	h	2	50	30051	1	Tap water operating hours (MSB)
	h	2	51	30052	1	Tap water operating hours (LSB)
		2	139	30140	1	Desired gear for tap water
53/55	°C	2	22	40023	100	Start temperature tap water
53/55	°C	2	23	40024	100	Stop temperature tap water

### 6.2 TWC

Position number	Units	Reference to	Address	De Facto Address	Scale	Description
	on/off	3	12	13	1	Enable TWC (EM)
63	active/inactive	3	45	10046	1	TWC supply line sensor alarm (EM)
56	active/inactive	3	51	10052	1	TWC circulation return sensor alarm (EM)
56	active/inactive	3	58	10059	1	TWC circulation return low temperature alarm (EM)
63	active/inactive	3	59	10060	1	TWC supply low temperature alarm (EM)
180	active/inactive	3	81	10082	1	Tap water end tank sensor alarm
31	on/off	3	230	10231	1	TWC supply line circulation pump control signal (EM)
115	on/off	3	234	10235	1	TWC end tank heater control signal (EM)
75	%	3	86	30087	100	TWC valve position (EM)
63	°C	3	95	30096	100	TWC supply line temperature (EM)
56	°C	3	96	30097	100	TWC return temperature (EM)
180	°C	3	98	30099	100	TWC end tank temperature (EM)
75	°C	3	31	40032	100	TWC mix valve set point (EM)
75	%	3	33	40034	100	TWC mix valve lowest allowed opening degree (EM)
75	%	3	34	40035	100	TWC mix valve highest allowed opening degree (EM)
115	°C	3	35	40036	100	TWC start temperature immersion heater (EM)
115	°C	3	37	40038	100	TWC stop temperature immersion heater (EM)

## 6.3 WCS

Position number	Units	Reference to	Address	De Facto Address	Scale	Description
	on/off	4	13	14	1	Enable WCS (EM)
54	active/inactive	4	44	10045	1	WCS return line sensor alarm (EM)
54	active/inactive	4	65	10066	1	WCS return line temperature deviation alarm (EM)
	on/off	4	232	10233	1	WCS regulation control signal (EM)
35	on/off	4	233	10234	1	WCS circulation pump control signal (EM)
73	%	4	85	30086	100	WCS valve position (EM)
54	°C	4	97	30098	100	WCS return line temperature (EM)
54	°C	4	32	40033	100	WCS return line set point (EM)
73	%	4	38	40039	100	WCS mix valve lowest allowed opening degree (EM)
73	%	4	39	40040	100	WCS mix valve highest allowed opening degree (EM)

## 7 Cooling

### 7.1 Cooling

Position number	Units	Reference to	Address	De Facto Address	Scale	Description
	On/Off	5	10	11	1	Enable active cooling
	On/Off	5	30	31	1	Enable surplus heat, borehole (no chiller)
	On/Off	5	33	34	1	Enable passive cooling (EM)
345	On/Off	5	78	10079	1	External start brine pump, read only
		5	141	30142	1	Desired gear for cooling

### 7.2 Cooling tank

Position number	Units	Reference to	Address	De Facto Address	Scale	Description
59	active/inactive	5	46	10047	1	Cooling tank sensor alarm (EM)
58	active/inactive	5	47	10048	1	Cooling supply line sensor alarm (EM)
59	active/inactive	5	68	10069	1	Cooling tank temperature deviation alarm (EM)
57	active/inactive	5	73	10074	1	Cooling tank return line sensor alarm (EM)
79	on/off	5	242	10243	1	Active cooling directional valve position (Borehole disconnected) (EM)
78	on/off	5	243	10244	1	Passive/Active cooling directional valve position (Cooling tank connected) (EM)
59	°C	5	104	30105	100	Cooling tank temperature (EM)
57	°C	5	105	30106	100	Cooling tank return line temperature (EM)
59	°C	5	105	40106	100	Start temp for cooling (EM)
59	°C	5	106	40107	100	Stop temp for cooling (EM)

### 7.3 Cooling circuit

Position number	Units	Reference to	Address	De Facto Address	Scale	Description
	on/off	5	23	24	1	Enable dew point calculation (EM)
181	active/inactive	5	48	10049	1	Cooling circuit return line sensor alarm (EM)
58	active/inactive	5	67	10068	1	Cooling circuit supply line temperature deviation alarm (EM)
422	active/inactive	5	70	10071	1	Humidity room sensor alarm
38	on/off	5	236	10237	1	Cooling circuit circulation pump control signal (EM)
	on/off	5	240	10241	1	Cooling circuit regulation control signal (EM)
422	°C	5	91	30092	100	Dew point room (EM)
74	%	5	92	30093	100	Cooling supply line mix valve position (EM)
181	°C	5	103	30104	100	Cooling circuit return line temperature (EM)
58	°C	5	106	30107	100	Cooling circuit supply line temperature (EM)

Position number	Units	Reference to	Address	De Facto Address	Scale	Description
74	on/off	5	137	30138	1	Mix valve cooling opening degree (EM2/3)
74	°C	5	30	40031	100	Cooling mix valve set point (EM)
74	%	5	49	40050	100	Cooling supply line mix valve: Lowest allowed opening degree (EM)
74	%	5	50	40051	100	Cooling supply line mix valve: Highest allowed opening degree (EM)

## 7.4 Surplus heat

Position number	Units	Reference to	Address	De Facto Address	Scale	Description
	on/off	5	29	30	1	Enable surplus heat, chiller (no borehole)
61	active/inactive	5	69	10070	1	Surplus heat temperature deviation alarm (EM)
182	active/inactive	5	71	10072	1	Surplus heat supply line sensor alarm (EM)
61	active/inactive	5	72	10073	1	Surplus heat return line sensor alarm (EM)
76	on/off	5	238	10239	1	Surplus heat directional valve position (EM)
39	on/off	5	239	10240	1	Surplus heat circulation pump control signal (EM)
	on/off	5	241	10242	1	Surplus heat regulation control signal (EM)
119	%	5	93	30094	100	Surplus heat fan speed (EM)
61	°C	5	117	30118	100	Surplus heat return line temperature (EM)
182	°C	5	118	30119	100	Surplus heat supply line temperature (EM)
251	%		414	30415	100	Surplus heat mixing valve position (EM)
61		5	48	40049	100	Surplus heat chiller set point (EM)
119	%	5	51	40052	100	Surplus heat opening degree for starting fan 1 (EM)
119	%	5	52	40053	100	Surplus heat opening degree for starting fan 2 (EM)
119	%	5	53	40054	100	Surplus heat opening degree for stopping fan 1 (EM)
119	%	5	54	40055	100	Surplus heat opening degree for stopping fan 2 (EM)
119	%	5	55	40056	100	Surplus heat lowest allowed opening degree (EM)
119	%	5	56	40057	100	Surplus heat highest allowed opening degree (EM)

## 8 Pool

### 8.1 Pool

Position number	Units	Reference to	Address	De Facto Address	Scale	Description
	on/off	6	28	29	1	Enable pool (EM)
	on/off	6	31	32	1	Enable external additional heater for pool (EM)
60	active/inactive	6	76	10077	1	Pool return line sensor alarm
342	on/off	6	77	10078	1	External stop for pool, read only (EM)
101	on/off	6	235	10236	1	Pool directional valve position (EM)
32	on/off	6	237	10238	1	Pool circulation pump control signal (EM)
	on/off	6	244	10245	1	Pool regulation control signal (EM)
250	%	6	94	30095	100	Pool supply line mix valve position (EM)
183	°C	6	119	30120	100	Pool supply line temperature (EM)
60	°C	6	120	30121	100	Pool return line temperature (EM)
		6	142	30143	1	Desired gear for pool
183	°C	6	58	40059	100	Pool charge set point (EM)
250	%	6	59	40060	100	Pool mix valve lowest allowed opening degree (EM)
250	%	6	60	40061	100	Pool mix valve highest allowed opening degree (EM)
60		6	299	40300	10	Set point return temp from pool to heat exchanger (EM)
60	K	6	300	40301	10	Set point pool hysteresis (EM)

## 9 Electric meter

### 9.1 Electric meter

For this function, the accessory "Current limiter" is required.

Position number	Units	Reference to	Address	De Facto Address	Scale	Description
		9	26	27	1	Enable current limitation
	A	9	69	30070	100	Electric meter L1 current (A)
	A	9	70	30071	100	Electric meter L2 current (A)
	A	9	71	30072	100	Electric meter L3 current (A)
	V	9	72	30073	100	Electric meter L1-0 voltage (V)
	V	9	73	30074	100	Electric meter L2-0 voltage (V)
	V	9	74	30075	100	Electric meter L3-0 voltage (V)
	V	9	75	30076	10	Electric meter L1-L2 voltage (V)
	V	9	76	30077	10	Electric meter L2-L3 voltage (V)
	V	9	77	30078	10	Electric meter L3-L1 voltage (V)
	W	9	78	30079	1	Electric meter L1 power (W)
	W	9	79	30080	1	Electric meter L2 power (W)
	W	9	80	30081	1	Electric meter L3 power (W)
	kWh	9	81	30082	1	Electric meter - meter value (kWh)
		9	83	30084	10	Electric meter kWh total (LSB)
		9	84	30085	10	Electric meter kWh total (MSB)

## 10 RSM - Refrigerant Safety Module

### 10.1 RSM - Refrigerant Safety Module

Position number	Units	Reference to	Address	De Facto Address	Scale	Description
	active/ inactive	11	247	10248	1	Refrigerant safety module internal failure. Only for Mega E.
	active/ inactive	11	248	10249	1	Refrigerant safety module internal failure. Only for Mega E.
	active/ inactive	11	249	10250	1	Ventilation test failed, pressure sensor triggered prior to started test. Only for Mega E.
	active/ inactive	11	250	10251	1	Ventilation test failed, pressure sensor did not trigger during the test. Only for Mega E.
	active/ inactive	11	251	10252	1	Refrigerant leakage detected. Only for Mega E.
	active/ inactive	11	252	10253	1	Refrigerant leakage sensor failure. Only for Mega E.
	active/ inactive	11	253	10254	1	Refrigerant safety module communication error. Only for Mega E.
	active/ inactive	11	254	10255	1	Ventilation test failed. Only for Mega E.
	enum	11	413	30414	1	Ventilation test status *8. Only for Mega E.

## 11 Footnotes

---

### 11.1 Footnotes

---

**Footnotes:**

\*1) 1: Manual operation, 2: Defrost, 3: Hot water, 4: Heat, 5: Active Cooling, 6: Pool, 7: Anti legionella, 8: Passive Cooling 98: Standby 99: No demand 100: OFF

\*2) 1: OFF, 2: Standby, 3: ON/Auto

\*3) Different heat pumps have different number of available gears.

For instance: Commercial can have 10, while domestic can have 9 gears.

\*4) These applies to Smart grid function. 1: EVU, 4: Normal, 5: Comfort, 6: Boost

\*5) Should always be set to 1 in auto mode

\*6) Bit 0: Manual operation Bit 1: Defrost, Bit 2: Hot water, Bit 3: Heat, Bit 4: Active Cooling, Bit 5: Pool, Bit 6: Anti legionella, Bit 7: Passive Cooling, Bit 8: Reserved, Bit 9: Standby, Bit 10: No demand, Bit 11: OFF

\*7) 0: Disable immersion heater, 2: Internal immersion heater enabled

\*8) -1: No recorded test, 0: Not initiated value, 1: Ventilation test in progress, 2: Latest Ventilation test was successful, 3: Latest Ventilation test failed.

Thermia AB reserves the right to make changes in the software protocol availability and related documents without further notice. By controlling and/or interacting with the heat pump the user takes full responsibility for any consequences. Thermia AB will not take any liability for damages on equipment, properties or personal injuries occurring as a consequence of any attempts of remotely controlling the heat pumps or system.







Thermia Heat Pumps  
Box 950  
SE 671 29 ARVIKA  
Phone +46 570 81300  
E-mail: [info@thermia.com](mailto:info@thermia.com)  
Internet: [www.thermia.com](http://www.thermia.com)

---

Thermia can accept no responsibility for possible errors in catalogues, brochures and other printed material. Thermia reserves the right to alter its products without notice. This also applies to products already on order provided that such alterations can be made without subsequential changes being necessary in specifications already agreed. All trademarks in this material are property of the respective companies. Thermia AB and the Thermia AB logotype are trademarks of Thermia AB. All rights reserved.

---